

CUSTOMER SPECIFICATION DWG

PRODUCT SPECIFICATION

REVISIONS		
REV.	DESCRIPTION	DATE
B	HINGE REDESIGN	11/11/20

NOTES:

1. DIMENSIONS IN BRACKETS [] ARE MILLIMETERS, FOR REFERENCE ONLY.
2. GRAIN DIRECTION PER ASME Y14.36M-1996 FOR SS SATIN FINISHES ONLY.

-GRAB BAR INCLUDED: GSS-180-QCR

-MATERIAL: SEAT TOP: 1/2" ONE-PIECE SOLID PHENOLIC
FRAME: 304 STAINLESS STEEL

-AVAILABLE FINISHES (IDENTIFY SUFFIX WHEN ORDERING)

SEAT TOP:

- PWS PHENOLIC WHITE ONE-PIECE SOLID
- PTS PHENOLIC TEAK ONE-PIECE SOLID
- PAS PHENOLIC ALMOND ONE-PIECE SOLID
- PW PHENOLIC WHITE 3" SLATS
- PT PHENOLIC TEAK 3" SLATS
- PA PHENOLIC ALMOND 3" SLATS

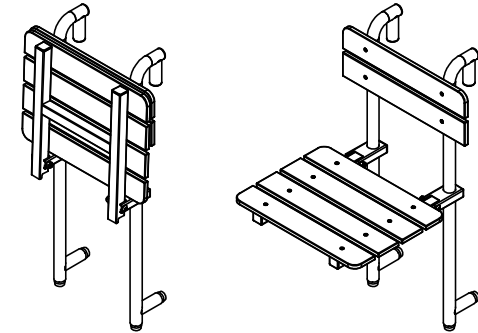
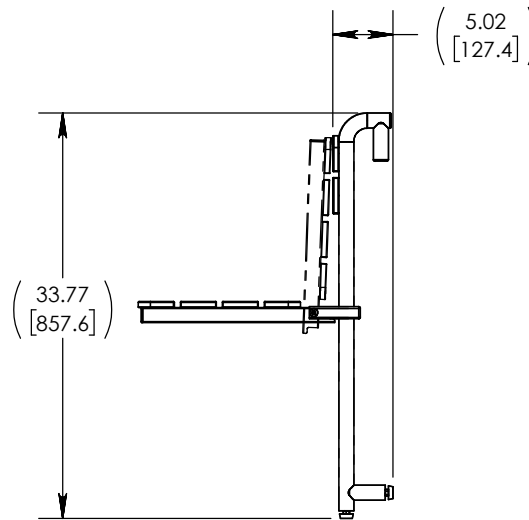
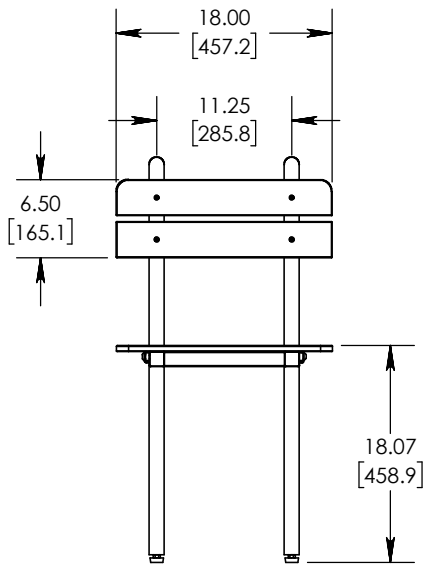
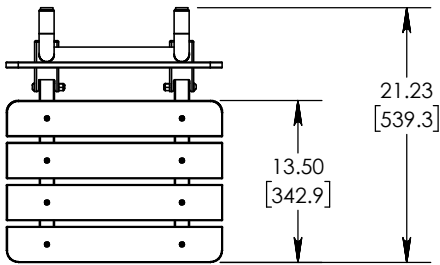

PROPRIETARY AND CONFIDENTIAL

THIS DRAWING AND THE INFORMATION CONTAINED HEREIN IS PROPERTY OF SEACHROME CORPORATION AND SHALL NOT BE REPRODUCED, COPIED, OR DISCLOSED IN WHOLE, OR IN PART, OR USED IN MANUFACTURING OR FOR ANY OTHER PURPOSE WITHOUT THE WRITTEN PERMISSION OF SEACHROME CORPORATION.

INTERPRET GEOMETRIC TOLERANCING PER: ASME Y14.5-2009
UNLESS OTHERWISE SPECIFIED:
DIMENSIONS ARE IN INCHES [MM]
TOLERANCES: DECIMALS
FRACTIONAL ±1/64 .X ±0.1
ANGLES ± 1° .XX ±0.02

DRAWN T. AYALA	08/10/20	DWG. NO. SSGBH-180160-PT	REV B
ENG APPR. J. AMOZOC	08/10/20	SIZE A DO NOT SCALE DRAWING	SCALE: 1:16 SHEET 1

SEACHROME

1906 EAST DOMINGUEZ
LONG BEACH, CA 90810
(310) 427-8010

CORPORATION

TITLE: PROFILE BENCH SEAT & GRAB BAR