

ASSEMBLY INSTRUCTIONS

PORTABLE TUB CHAIR

PLEASE READ THESE ASSEMBLY INSTRUCTIONS THOROUGHLY PRIOR TO ASSEMBLING THIS TUB CHAIR

IMPORTANT: THIS PRODUCT SHOULD ONLY BE ASSEMBLED BY QUALIFIED AND TRAINED PERSONNEL

FAILURE TO FOLLOW THESE INSTRUCTIONS COULD LEAD TO IMPROPER ASSEMBLY OF THE TUB CHAIR, AND/OR SERIOUS BODILY INJURY IN USE. IN ADDITION, ALL WARRANTIES, EXPRESS OR IMPLIED, WILL BE NULL & VOID DUE TO IMPROPER ASSEMBLY OF THIS PRODUCT. THE MANUFACTURER DOES NOT ASSUME ANY LIABILITY FOR DAMAGE RESULTING FROM SERVICES PERFORMED BY OTHERS, OR FAULTY ASSEMBLY, MISUSE OR MISAPPLICATION OF GOODS.

THIS PRODUCT IS DESIGNED TO MEET OR EXCEED ALL LOAD REQUIREMENTS ESTABLISHED IN THE AMERICANS WITH DISABILITIES (ADA) ACT AND/OR FEDERAL SPECIFICATION WW-P-541/8b AT 250 POUNDS OF FORCE.

MAXIMUM WEIGHT CAPACITY FOR THIS PRODUCT SHALL NOT EXCEED 250 LBS. WHEN PROPERLY ASSEMBLED.

1. Remove the Portable Tub Chair components from the shipping carton.

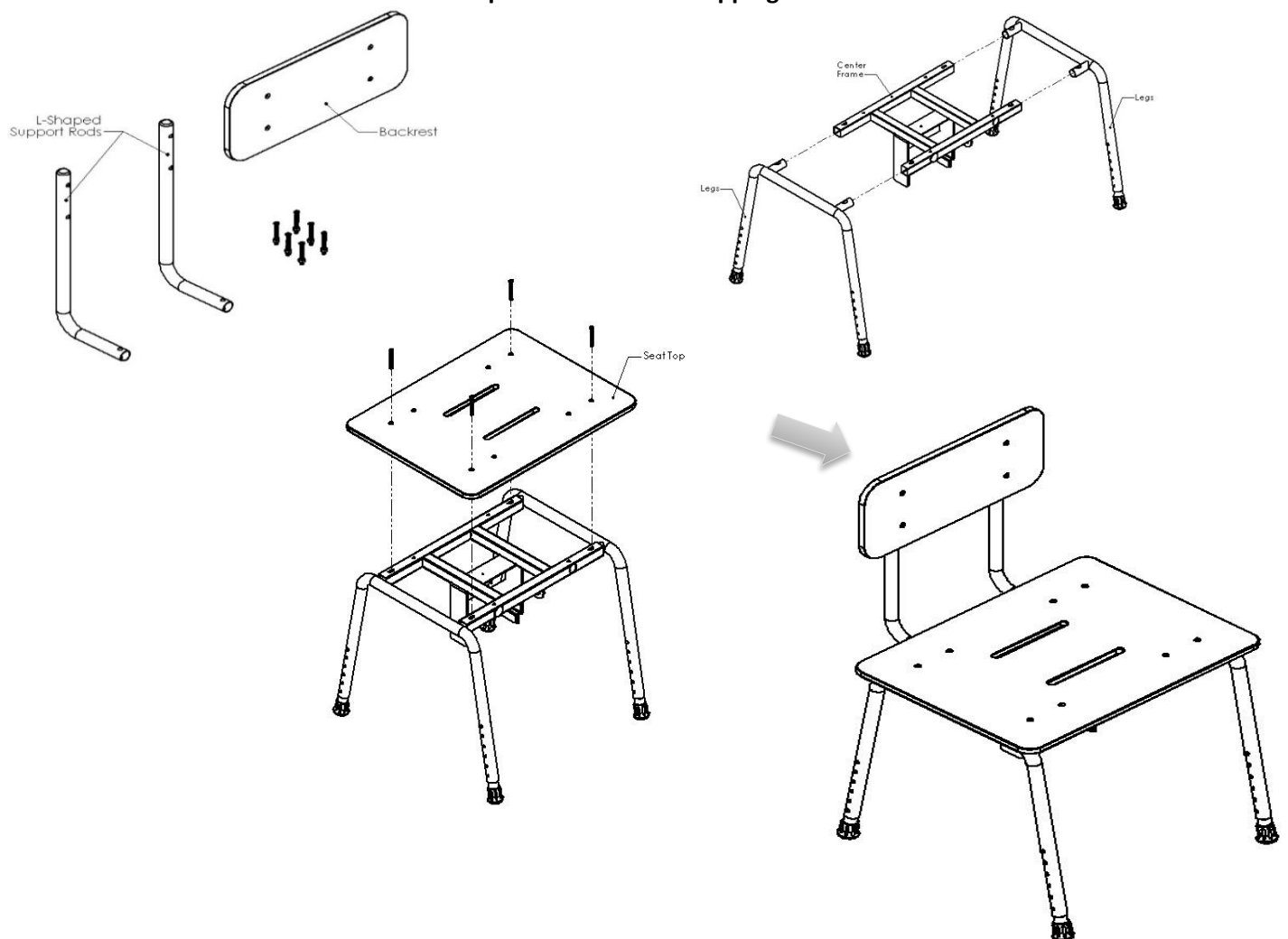

Step #1: Backrest Assembly

Assemble backrest by aligning the holes with each L-Shaped Support Rod with the holes in the phenolic backrest. (See Fig. 1)

Use (4) 10-24 x 2" L Phillips Flat Head Screws and (4) 10-24 Nylon Lock Nuts (provided) to fasten the Support Rods to the backrest. Tighten with Phillips Screwdriver and 3/8" Socket & Ratchet (not provided).

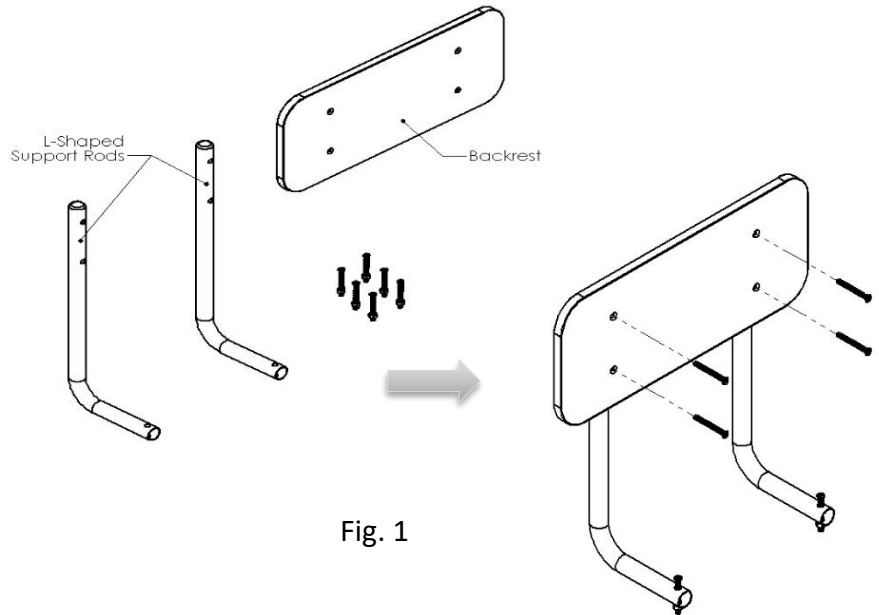

Fig. 1

Step #2: Seat Frame Assembly

Align center frame with tub clamp to each leg.

(See Fig. 2)

Insert 7/8" round tubing of each leg into 1" square tubing on the center frame as shown.

Make sure holes in the center frame align with leg holes for Step 3.

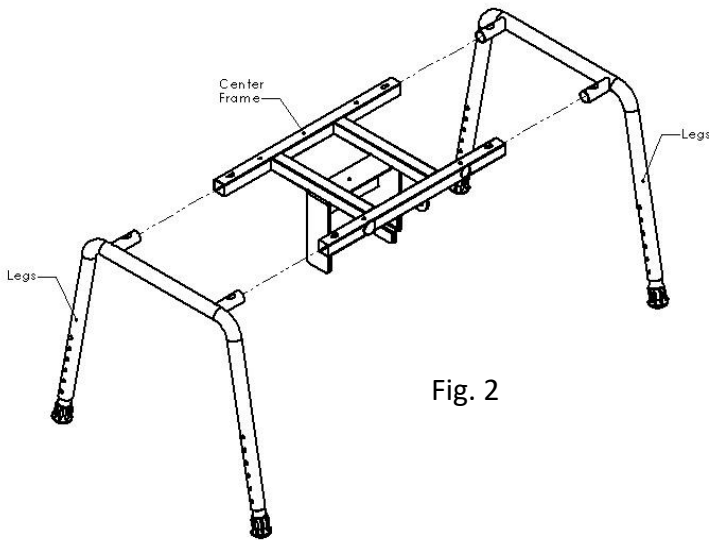

Fig. 2

Step #3: Seat Assembly

Place phenolic seat top onto preassembled frame and align all holes. Use (4) 10-24 x 2" Phillips Flat Head Screws (provided) and insert them into the (4) holes of the seat top. (See Fig. 3)

Use (4) 10-24 Nylon Lock Nuts (provided) and tighten all hardware with Phillips Screwdriver and 3/8" Socket & Ratchet (not provided).

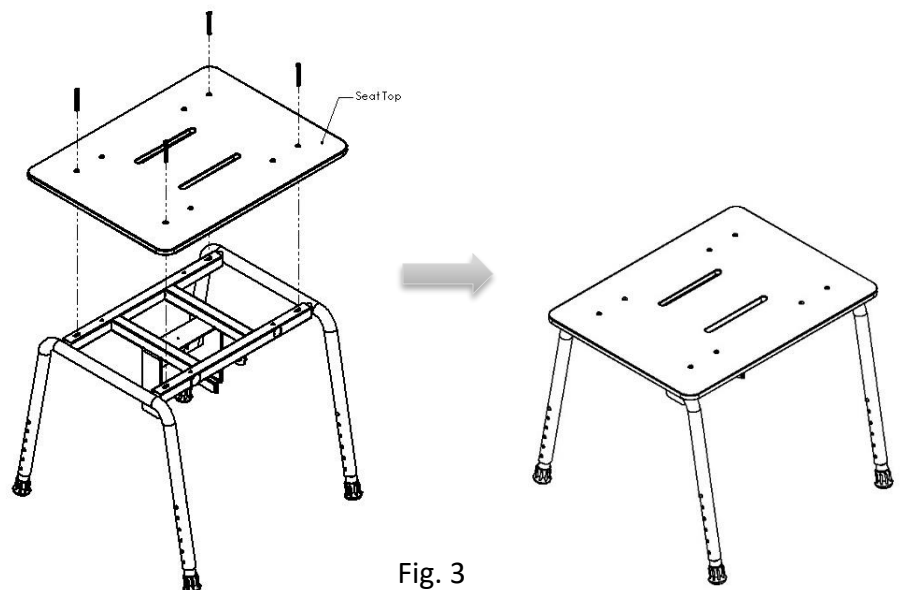

Fig. 3

Step #4: Final Assembly

Align holes on the backrest assembly with holes on the seat frame assembly as desired.

Use (2) 10-24 x 2" L Phillips Flat Head Screws (provided) and place them into the holes designated for the backrest. (See Fig. 4)

Use (2) 10-24 Nylon Lock Nuts (provided) and tighten all hardware with Phillips Screwdriver and 3/8" Socket & Ratchet (not provided).

Check to ensure that all hardware is secure. Do NOT over tighten.

Place the final seat assembly on a dry, flat surface to ensure all (4) legs are level, and the seat performs as required.

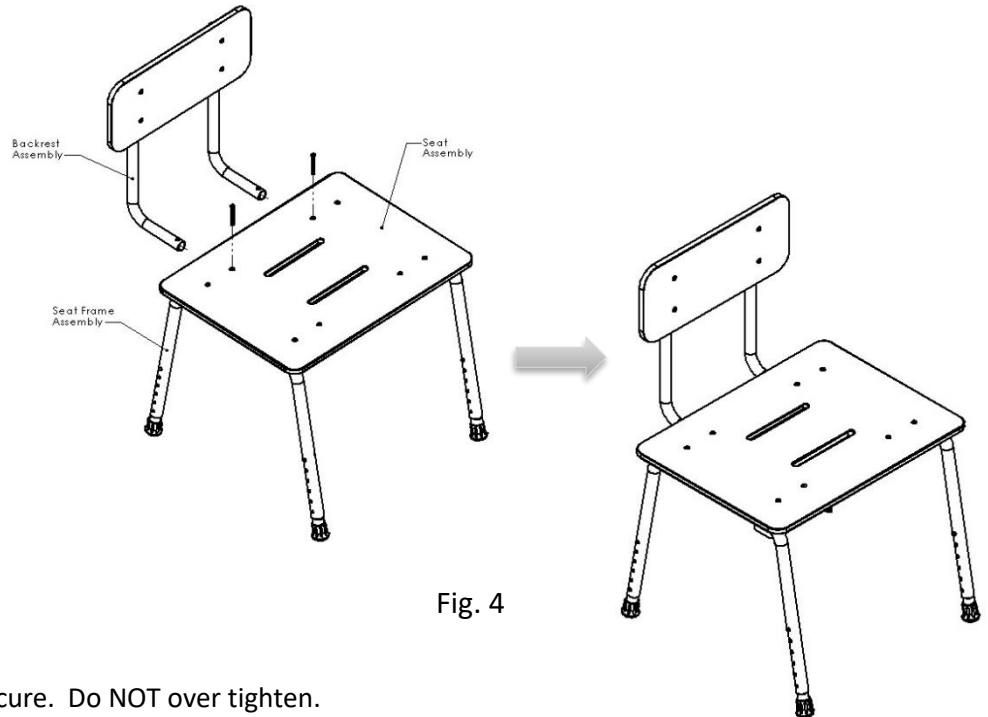

Fig. 4

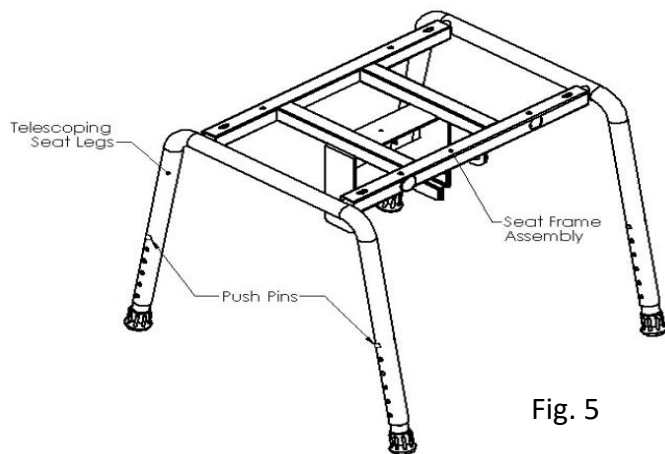

Fig. 5

Step #5: Seat Leg Height Adjustment

Press both push pins to extend or shorten the telescoping seat legs on the seat frame assembly (See Fig. 5) to set the desired height for the seat assembly.

CAUTION: When final adjustments have been made to the seat assembly, the seat must be level and stable with all (4) telescoping seat legs secure on the floor before use, for the seat to perform as required.

MAXIMUM WEIGHT CAPACITY FOR THIS PRODUCT SHALL NOT EXCEED 250 LBS. WHEN PROPERLY ASSEMBLED.

Hardware Provided: (10) 10-24 X 2" Length Stainless Steel Phillips Flat Head Screws
(10) 10-24 Nylon Lock Nuts

Tools required: Phillips Screwdriver, 3/8" Socket, Ratchet

THIS COMPLETES THE ASSEMBLY OF THE PORTABLE TUB CHAIR.