

# SEACHROME

Seachrome Corporation  
1906 East Dominguez Street  
Long Beach, California 90810  
Phone: (800) 955-2476  
Fax: (800) 444-3380

Description:

## SCM-950 Towel Ring

Customer:

Customer Part #

08-24-2015

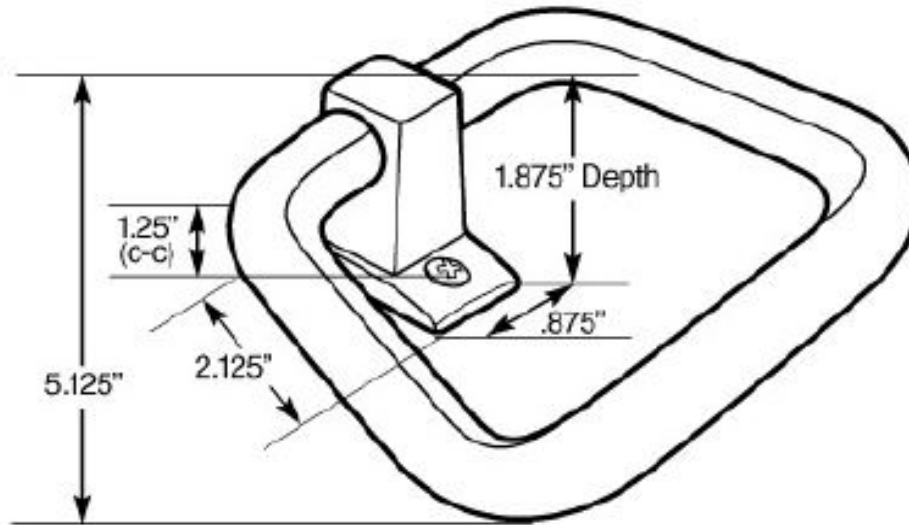

### Specifications:

Towel Ring post is die cast from highest quality zinc alloy (zamac). Castings are triple plated with a polished chrome finish. Ring is clear acrylic plastic.

### Installation:

1. Place unit on wall in desired location.
2. Mark location of holes. Drill starter holes.
3. Attach unit to wall with 1 1/2" screws (provided).

Note: Wood blocking is preferable behind all wall surfaces. If wood blocking is not available, the following optional fasteners are suggested:  
Tile/Masonry – Plastic or Lead Anchors;  
Plaster/Drywall – Toggle Bolts.

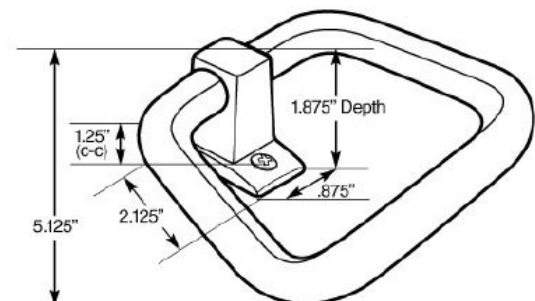

This drawing and the information contained herein is proprietary to Seachrome Corp. and shall not be reproduced, copied or disclosed in whole, or part, or used for manufacturing or for any other purpose without the written permission of Seachrome Corporation.

This information is subject to change without formal notice. If you need any additional help, Seachrome Corporation has a technical support staff that is ready to assist you.